

## Features

- 4:1 Wide Input Range
- Operating Temperature Range: -40~100°C
- Approved to cURus, UKCA, CE
- Approved to IEC/UL/EN62368-1
- Efficiency upto 86%
- EMC Class A & B Dependent on Input
- Single & Dual 6W Output Models
- Small Size & Low Profile SIP8 Package 0.86x 0.36x 0.44 Inch



Ideal Power's 43RDL06-xyzW 5-6W Series SIP DC/DC Converters are certified to cURus, UKCA, CE, RoHS, REACH & IEC/UL/EN 62368-1, EN 50155 Standards and comply with the relevant Efficiency Regulations. These are primarily used in ITE, Video & Audio, Railway Industries and customised solutions are available upon request.

## Models

Model Number	Input Range	Output Voltage	Output Current @Full Load mA	Input Current @No Load mA	Efficiency %	Maximum Capacitor Load µF
43RDL06-24S3P3W	9~36	3.3	1500	4	81	2200
43RDL06-24S05W	9~36	5	1200	4	84	1100
43RDL06-24S09W	9~36	9	666	4	86	680
43RDL06-24S12W	9~36	12	500	4	87	470
43RDL06-24S15W	9~36	15	400	4	88	470
43RDL06-24S24W	9~36	24	250	4	87	180
43RDL06-24D05W	9~36	±5	±600	6	84	±680
43RDL06-24D12W	9~36	±12	±250	6	87	±330
43RDL06-24D15W	9~36	±15	±200	8	87	±180
43RDL06-48S3P3W	18~75	3.3	1500	4	81	2200
43RDL06-48S05W	18~75	5	1200	4	84	1100
43RDL06-48S09W	18~75	9	666	4	85	680
43RDL06-48S12W	18~75	12	500	4	87	470
43RDL06-48S15W	18~75	15	400	4	87	470
43RDL06-48S24W	18~75	24	250	4	87	180
43RDL06-48D05W	18~75	±5	±600	6	84	±680
43RDL06-48D12W	18~75	±12	±250	6	87	±330
43RDL06-48D15W	18~75	±15	±200	8	87	±180
43RDL06-110S3P3W	43~160	3.3	1500	2	80	2200
43RDL06-110S05W	43~160	5	1200	2	83	1100
43RDL06-110S09W	43~160	9	666	2	85	680
43RDL06-110S12W	43~160	12	500	2	86	470
43RDL06-110S15W	43~160	15	400	2	86	470
43RDL06-110S24W	43~160	24	250	2	86	180
43RDL06-110D05W	43~160	±5	±600	2	83	±680

**Models (Continued)**

43RDL06-110D12W	43~160	±12	±250	2	86	±330
43RDL06-110D15W	43~160	±15	±200	2	86	±180

**Input Specifications**

Parameter	Conditions		Min	Typ	Max	Unit
Operating input voltage range	24Vin(nom)		9	24	36	VDC
	48Vin(nom)		18	48	75	
	110Vin(nom)		43	110	160	
Start up time	Constant resistive load	Power up Remote ON/OFF		50	75	ms
				50	75	
Input surge voltage	1 second, max.	24Vin(nom)			50	VDC
		48Vin(nom)			100	
		110Vin(nom)			185	
Input filter				Capacitor type		
Remote ON/OFF	Referred to -Vin pin	DC-DC ON DC-DC OFF		Open or 0 ~ 0.5VDC 3 ~		
		Input current of Ctrl pin	2	12VDC		
		Remote off input current		4	mA	
			2.5	mA		

**Output Specifications**

Parameter	Conditions		Min	Typ	Max	Unit
Voltage accuracy			-1.0		+1.0 %	
Line regulation	Low Line to High Line at Full Load		-0.2		+0.2 %	
Load regulation	No Load to Full Load	Single Dual	-0.5		+0.5	%
			-1.0		+1.0	
Cross regulation	Asymmetrical load 25%/100% FL	Dual	-5.0		+5.0 %	
Ripple and noise	Measured by 20MHz bandwidth With a 1µF/50V X7R MLCC			50	75	mVp-p
Temperature coefficient			-0.02		+0.02	%/°C
Transient response recovery time	25% load step change			250		µs
Over load protection	% of lout rated; Hiccup mode			180 %		
Short circuit protection				Continuous, automatics recovery		

**General Specifications**

Parameter	Conditions		Min	Typ	Max	Unit
Isolation voltage	1 minute	Input to Output	3000			VDC
		Input (Output) to Case	1500			
Isolation resistance	500VDC		1			GΩ
Isolation capacitance					100	pF
Switching frequency		110Vin	270	300	330	kHz
		Others	520	580	640	
Safety approvals	IEC/ EN/ UL62368-1					UL:E193009 CB:UL(Demko)
Standard approvals	EN50155 EN45545-2					
Case material						Copper
Base material						None
Potting material						Silicone (UL94 V-0)
Weight						5.9g (0.21oz)
MTBF	MIL-HDBK-217F, Full load					2.948 x 10 <sup>6</sup> hrs

**Environmental Specifications**

Parameter	Conditions	Min	Typ	Max	Unit
Operating case temperature	With derating	-40		+100	°C
	M3 version With derating	-55		+100	
Maximum case temperature				100	°C
Storage temperature range		-55		+125	°C
Thermal shock					MIL-STD-810F
Shock					EN61373, MIL-STD-810F
Vibration					EN61373, MIL-STD-810F
Relative humidity					5% to 95% RH

**EMC Specifications**

Parameter	Conditions	Level
EMI	EN55032, EN50121-3-2 With external components	Class A, Class B
EMS	EN55024, EN50121-3-2	
ESD	EN61000-4-2 Air $\pm$ 8kV and Contact $\pm$ 6kV	Perf. Criteria A
Radiated immunity	EN61000-4-3 20V/m	Perf. Criteria A
Fast transient	EN61000-4-4 $\pm$ 2kV	Perf. Criteria A
	43RDL06-24□□□W	With an aluminum electrolytic capacitor (Nippon chemi-con KY series, 220 $\mu$ F/100V) and a TVS (SMDJ70A, 70V, 3000Watt peak pulse power) to connect in parallel.
	43RDL06-48□□□W	With an aluminum electrolytic capacitor (Nippon chemi-con KY series, 220 $\mu$ F/100V) and a TVS (SMDJ120A, 120V, 3000Watt peak pulse power) to connect in parallel.
	43RDL06-110□□□W	With an aluminum electrolytic capacitor (Nippon chemi-con KXJ series, 150 $\mu$ F/200V) and a TVS (SMB250A, 250V, 600Watt peak pulse power) to connect in parallel.
Surge	EN61000-4-5 $\pm$ 2kV	Perf. Criteria A
	43RDL06-24□□□W	With an aluminum electrolytic capacitor (Nippon chemi-con KY series, 220 $\mu$ F/100V) and a TVS (SMDJ70A, 70V, 3000Watt peak pulse power) to connect in parallel.
	43RDL06-48□□□W	With an aluminum electrolytic capacitor (Nippon chemi-con KY series, 220 $\mu$ F/100V) and a TVS (SMDJ120A, 120V, 3000Watt peak pulse power) to connect in parallel.
	43RDL06-110□□□W	With an aluminum electrolytic capacitor (Nippon chemi-con KXJ series, 150 $\mu$ F/200V) and a TVS (SMB250A, 250V, 600Watt peak pulse power) to connect in parallel.
Conducted immunity	EN61000-4-6 10Vr.m.s	Perf. Criteria A
Power frequency magnetic field	EN61000-4-8 100A/m continuous; 1000A/m 1 second	Perf. Criteria A

## Characteristic Curve

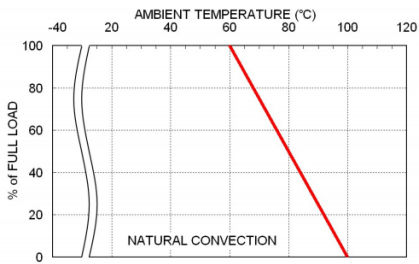

43RDL06-110S05W Derating Curve

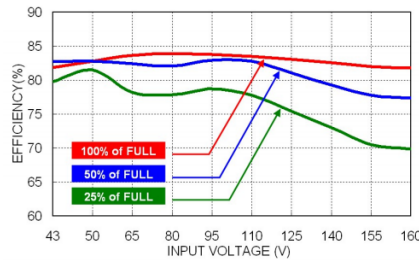

43RDL06-110S05W Efficiency vs. Input Voltage

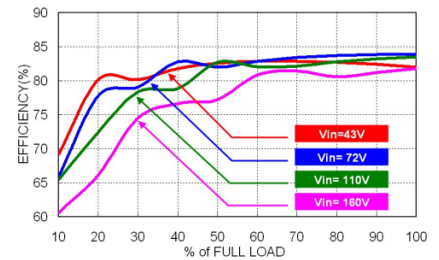

43RDL06-110S05W Efficiency vs. Output Load

The table based on the information provided in this data sheet on inrush energy and maximum DC input current at low Vin.

## Fuse Consideration

This power module is not internally fused. An input line fuse must always be used.

This encapsulated power module can be used in a wide variety of applications, ranging from simple stand-alone operation to an integrated part of sophisticated power architecture.

To maximum flexibility, internal fusing is not included; however, to achieve maximum safety and system protection, always use an input line fuse. The input line fuse suggest as below:

Model	Fuse Rating (A)	Fuse Type
43RDL06-24□□□W	1.25	Slow-Blow
43RDL06-48□□□W	0.63	Slow-Blow
43RDL06-110□□□W	0.315	Slow-Blow

## Mechanical Drawing

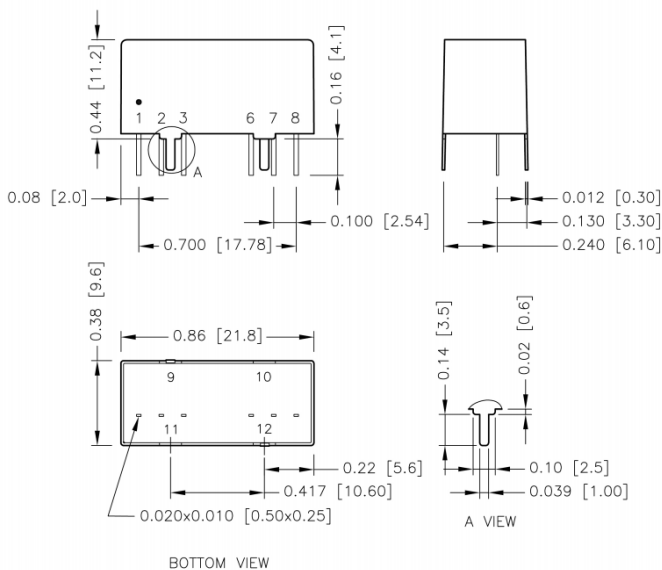

### PIN CONNECTION

PIN	SINGLE	DUAL
1	-Vin	-Vin
2	+Vin	+Vin
3	Ctrl	Ctrl
6	+Vout	+Vout
7	-Vout	Common
8	NC	-Vout
9	Case	Case
10	Stand off	Stand off
11	Stand off	Stand off
12	Case	Case

- All dimensions in inch [mm]
- Tolerance :x.xxx±0.02 [x.xx±0.5]  
x.xxx±0.01 [x.xx±0.25]
- Pin dimension tolerance ±0.004[0.10]

\* Case pins should not be connected to any circuit.

## Recommended Pad Layout

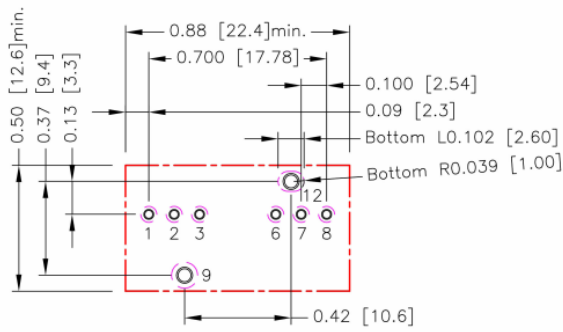

All dimensions in inch[mm]  
 Pad size(lead free recommended)  
 Through hole 1.2.3.6.7.8:  $\Phi 0.031$ [0.80]  
 Through hole 9.12:  $\Phi 0.051$ [1.30]  
 Top view pad 1.2.3.6.7.8:  $\Phi 0.039$ [1.00]  
 Top view pad 9.12:  $\Phi 0.064$ [1.63]  
 Bottom view pad 1.2.3.6.7.8:  $\Phi 0.063$ [1.60]  
 Bottom view pad 9:  $\Phi 0.102$ [2.60]  
 Bottom view pad 12: Groove R0.039[1.00]L0.102[2.60]

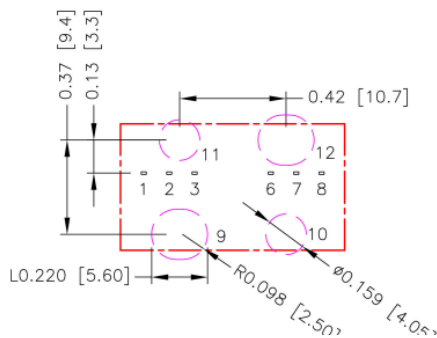

Area 9.10.11.12 don't layout  
 Area 10.11 size:  $\Phi 0.159$ [4.05]  
 Area 9.12 size: Groove R0.098[2.50]L0.220[5.60]  
 The layout distance between Pin3 and Pin6 is at least 3mm

## Thermal Considerations

The power module operates in a variety of thermal environments.

However, sufficient cooling should be provided to help ensure reliable operation of the unit. Heat is removed by conduction, convection, and radiation to the surrounding Environment. Proper cooling can be verified by measuring the point as the figure below. The temperature at this location should not exceed "Maximum case temperature".

When Operating, adequate cooling must be provided to maintain the test point temperature at or below "Maximum case temperature". You can limit this Temperature to a lower value for extremely high reliability.

- Thermal test condition with vertical direction by natural convection (20LFM).

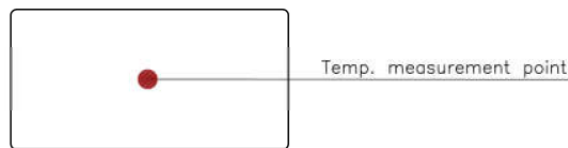

TOP VIEW